

# Residential Products Pricing and Ordering

NeoTherm ..... 2  
FT Series Wall ..... 4  
FT Series Floor ..... 5  
Mini-Therm JX..... 6

Laars-Stor ..... 8  
Combi Heat ..... 8  
Buffer Tank ..... 8



# NeoTherm 80-285 Pricing - Effective December 6, 2021

## Residential Modulating Condensing Boilers

### Standard Features

- High condensing efficiency
- Modulation down to 20% of full fire (5:1 turndown)
- Sealed combustion chamber
- Pre-mix stainless steel burner
- Low NOx system exceeds the most stringent regulations for air quality - 10ppm NOx
- Horizontal or vertical direct vent
- Horizontal vent and air terminals
- Vent and air pipe lengths of up to 100 equivalent feet (each)
- Built-in condensate trap
- Vent temperature cutoff
- Indirect water heater priority (sensor included)
- ASME 30psi (207kPa) working pressure heat exchanger
- Stainless steel heat exchanger with welded construction
- ASME "H" stamp
- 30psi (207kPa) ASME rated pressure relief valve
- Temperature and pressure gauge
- Drain valve
- Multiple pump control for boiler pump, system pump, and indirect domestic water pump, each with delay
- Optional pump (sized to model) available for field installation
- Electronic PID modulating control
- Direct spark ignition
- Large user interface and display
- Alarm output
- Accepts external (4-20mA or 0-10VDC) modulation signal
- Outdoor reset (sensor included)
- On/Off toggle switch
- Manual reset high limit
- Burner site glass
- Flue gas temperature cutoff
- Zero clearance to combustible surfaces
- 12-year limited warranty

### Model Nomenclature

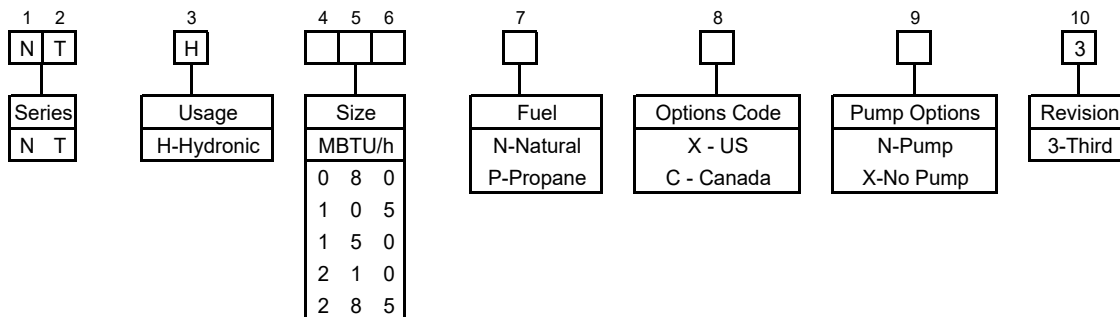

### Pricing

Factory Pump Shipped With Unit	
U.S. Model	List Price
NTH 080 (N,P) X N 3	\$7,523
NTH 105 (N,P) X N 3	\$8,473
NTH 150 (N,P) X N 3	\$9,527
NTH 210 (N,P) X N 3	\$10,904
NTH 285 (N,P) X N 3	\$14,296
Canada Model	List Price
NTH 080 (N,P) C N 3	\$7,523
NTH 105 (N,P) C N 3	\$8,473
NTH 150 (N,P) C N 3	\$9,527
NTH 210 (N,P) C N 3	\$10,904
NTH 285 (N,P) C N 3	\$14,296

Less Factory Pump	
U.S. Model	List Price
NTH 080 (N,P) X X 3	\$7,337
NTH 105 (N,P) X X 3	\$8,129
NTH 150 (N,P) X X 3	\$9,184
NTH 210 (N,P) X X 3	\$10,491
NTH 285 (N,P) X X 3	\$13,714
Canada Model	List Price
NTH 080 (N,P) C X 3	\$7,337
NTH 105 (N,P) C X 3	\$8,129
NTH 150 (N,P) C X 3	\$9,184
NTH 210 (N,P) C X 3	\$10,491
NTH 285 (N,P) C X 3	\$13,714

List prices for U.S. models include a PVC vent terminal and intake air terminal, a "starter section" of CPVC vent pipe, and adapter for standard PVC pipe.

# NeoTherm 80-285 Pricing - Effective December 6, 2021

## Residential Modulating Condensing Boilers

### Factory Mounted Options

		<i>Order kit number as separate line item</i>				
		<i>080</i>	<i>105</i>	<i>150</i>	<i>210</i>	<i>285</i>
Additional auto reset high limit	Kit #	<u>KM002701</u>	<u>KM002701</u>	<u>KM002701</u>	<u>KM002701</u>	<u>KM002701</u>
	List Price	\$124	\$124	\$124	\$124	\$124
Alarm bell for ignition failure	Kit #	<u>KM003100</u>	<u>KM003100</u>	<u>KM003100</u>	<u>KM003100</u>	<u>KM003100</u>
	List Price	\$696	\$696	\$696	\$696	\$696
50psi relief valve and max. rating	Kit #	<u>KM002906</u>	<u>KM002906</u>	<u>KM002906</u>	<u>KM002906</u>	<u>KM002902</u>
	List Price	no charge	no charge	no charge	no charge	no charge

### Accessories for Field Mounting

		<i>Order kit number as separate line item</i>				
		<i>080</i>	<i>105</i>	<i>150</i>	<i>210</i>	<i>285</i>
Water flow switch	Kit #	<u>CA004801</u>	<u>CA004801</u>	<u>CA004801</u>	<u>CA004801</u>	<u>CA004802</u>
	List Price	\$261	\$261	\$261	\$261	\$261
High & low gas pressure switches	Kit #	<u>CA005700</u>	<u>CA005700</u>	<u>CA005700</u>	<u>CA005700</u>	<u>CA005700</u>
	List Price	\$543	\$543	\$543	\$543	\$543
Boiler pump	Kit #	<u>CA006900</u>	<u>CA006901</u>	<u>CA006902</u>	<u>CA006903</u>	<u>CA006800</u>
	List Price	\$485	\$976	\$976	\$1,037	\$915
Common vent kit (One kit required for each NeoTherm unit)	Kit #	<u>CA016400</u>	<u>CA016400</u>	<u>CA016401</u>	<u>CA016401</u>	<u>CA016402</u>
	List Price	\$1,184	\$1,184	\$1,184	\$1,184	\$1,212
Concentric vent terminal, 2"	Kit #	<u>239-44069-02</u>	<u>239-44069-02</u>	N/A	N/A	N/A
	List Price	\$133	\$133			
Concentric vent terminal, 3"	Kit #	<u>239-44069-01</u>	<u>239-44069-01</u>	<u>239-44069-01</u>	<u>239-44069-01</u>	<u>239-44069-01</u>
	List Price	\$133	\$133	\$133	\$133	\$133
Concentric flush-mount vent terminal, 2"	Kit #	<u>CA010100</u>	<u>CA010100</u>	N/A	N/A	N/A
	List Price	\$120	\$120			
Concentric flush-mount vent terminal, 3"	Kit #	<u>CA010101</u>	<u>CA010101</u>	<u>CA010101</u>	<u>CA010101</u>	<u>CA010101</u>
	List Price	\$120	\$120	\$120	\$120	\$120
Concentric flush-mount vent terminal, 4"	Kit #	N/A	N/A	N/A	N/A	<u>CA010102</u>
	List Price					\$120
Propane conversion kit	Kit #	<u>CA006201</u>	<u>CA006202</u>	<u>CA006203</u>	<u>CA006204</u>	<u>CA006205</u>
	List Price	\$64	\$64	\$64	\$64	\$64
Condensate neutralizer kit	Kit #	<u>A2123601</u>	<u>A2123601</u>	<u>A2123601</u>	<u>A2123601</u>	<u>A2123602</u>
	List Price	\$165	\$165	\$165	\$165	\$264

# FT Series Wall Hung Pricing - Effective December 6, 2021

## Residential Fire Tube Condensing Wall-Mount Boilers and Combi Units

### Standard Features

- Stainless steel heat exchanger with finned aluminum core fire tubes, welded construction
- ASME "H" stamp
- ASME 30 psi (207kPa) working pressure heat exchanger
- 95% AFUE
- Modulation:  
5:1 turndown for model 100  
10:1 turndown for model 140/199
- Stainless steel DHW indirect tank storage heat exchanger (combi only)
- DHW priority
- Inlet DHW filter (combi only)
- Boiler pump, wired and mounted
- 30psi (207kPa) ASME PRV
- Pressure gauge
- Sealed combustion chamber
- Pre-mix ceramic fiber burner
- Low NOx system exceeds the most stringent regulations for air quality
- Horizontal or vertical direct vent
- Vent and air pipe lengths of up to 100 equivalent feet (each)
- Electronic PID modulating control
- Cascades 20 heating only units
- Large user interface and display
- Outdoor reset (sensor included)
- Accepts 0-10VDC external setpoint
- Manual reset high limit
- Customizable freeze protection
- Direct spark ignition
- Gas leak detection
- Built-in condensate trap and drain
- Automatic air vent
- Boiler water pressure switch
- Blocked vent pressure switch
- Blocked condensate pressure switch
- Burner site glass
- Wall mounting bracket
- Screens for vent and air pipe
- Propane conversion kit
- Limited Warranty:
  - 10-year heat exchanger
  - 5-year parts

### Model Nomenclature

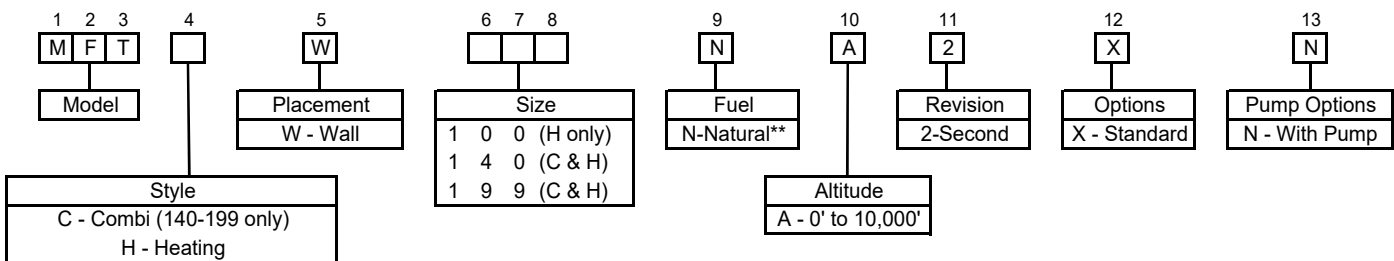

\*\*All units are shipped with propane conversion kits

### Pricing

Model	Input BTU/hr	List Price
<b>Wall-Mounted Combination Boiler and Water Heater</b>		
MFTCW140NA2XN	140,000	\$4,771
MFTCW199NA2XN	199,000	\$5,336

Model	Input BTU/hr	List Price
<b>Wall-Mounted Heating Only Boiler</b>		
MFTHW100NA2XN	100,000	\$4,019
MFTHW140NA2XN	140,000	\$4,332
MFTHW199NA2XN	199,000	\$4,639

### Accessories for Field Mounting

Description	Part Number	List Price
Horizontal Concentric 2" PVC Termination	239-44069-02	\$133
Horizontal Concentric 3" PVC Termination	239-44069-01	\$133
Concentric Flush-Mount 2" Vent Terminal	CA010100	\$120
Concentric Flush-Mount 3" Vent Terminal	CA010101	\$120
Neutralizer Kit	A2123601	\$165
Manifold Kit, Combi Models MFTCW 140 & 199	P2134400	\$552
Manifold Kit, Heat Only Models MFTHW 80-140	P2135900	\$780
Manifold Kit, Heat Only Models MFTHW 199	P2135800	\$829

#### CASCADE ITEMS (For heating only MFTHW models)

- Up to 20 heating only models can be cascaded together.
- Each cascade system requires one sensor for system, and one cable for each boiler.

Communication Cable (one required for each heater)	FT1861	\$10
Cascade sensor (one required for each cascade system)	FT1868	\$86

# FT Series Floor-Standing Pricing - Effective December 6, 2021

## Residential Fire Tube Condensing Floor-Standing Boiler and Combi Units

### Standard Features

- High condensing efficiency 95% AFUE
- ASME 30psi (207kPa) working pressure
- ASME "H" stamp
- Stainless steel fire tube heat exchanger with welded construction
- Integral stainless steel mini boiler tank serves as low loss header and indirect DHW tank
- Low lead compliant
- Boiler pump, wired and mounted inside jacket
- Full modulation 100% to 10% (10:1 turndown)
- Electronic PID modulating control
- Large user interface and display
- Receptacle for condensate pump
- Supply & return boiler sensors
- Smart DHW priority
- Cascade up to 20 units
- Bonus TT connection for high temp zone
- Accepts external (0-10VDC) temperature setpoint
- Connection for DHW recirculation pump
- Outdoor reset (sensor included)
- Customizable freeze protection
- Anti-short cycling
- Direct spark ignition
- Manual reset high limit
- Sealed combustion chamber
- Natural gas with propane conversion kit included
- Horizontal or vertical direct vent
- Concentric or two-pipe venting options
- Vent and air pipe lengths of up to 100 equivalent feet (each)
- Vent with PVC, CPVC, stainless steel, or polypropylene
- Built-in condensate trap and drain, priming not required
- 3-in-1 brass pipe adapter for air vent, PRV & opt. LWCO
- 30 psi (207kPa) pressure relief valve
- Removable / cleanable air filter
- Inlet DHW filter (combi only)
- Adjustable leveling feet
- Three service panels
- Gas leak detection
- Automatic air vent
- Pressure gauge
- Boiler water pressure switch
- Blocked vent pressure switch
- Blocked condensate switch
- Burner site glass
- 10-year limited warranty

### Model Nomenclature

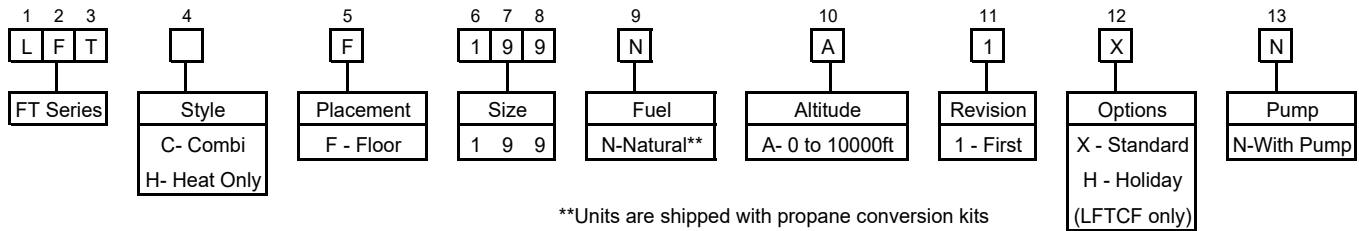

### Pricing

Model	Description	Input MBH	List Price
LFTCF199NA1XN	FT Series Combi Floor Standing	199	\$6,592
LFTHF199NA1XN	FT Series Heat Only Floor Standing	199	\$6,077
LFTCF199NA1HN	FT Series Combi Floor Standing w/ Holiday Switch	199	\$6,592

### Accessories for Field Mounting

Description	Part Number	List Price
Domestic Water Recirc Sensor	FT1868	\$86
Neutralizer & Pump Kit (fits inside boiler cabinet)	FT3007	\$521
Horizontal Concentric 2" PVC Termination	239-44069-02	\$133
Horizontal Concentric 3" PVC Termination	239-44069-01	\$133
Concentric Flush-Mount 2" Vent Terminal	CA010100	\$120
Concentric Flush-Mount 3" Vent Terminal	CA010101	\$120
Stainless Steel Concentric Appliance Adaptor	FT3006	\$678
Polypropylene Concentric Appliance Adaptor/Starter Kit	FT3002	\$602
Polypropylene to Heat-Fab Adaptor	FT3003	\$563
Polypropylene Telescopic Concentric and 90° Elbow Kit	FT3004	\$761
Polypropylene Offset Kit	FT3001	\$162
2" Vent/Air Pipe Screen (boiler is shipped with 3" screens)	FT1508	\$14

**CASCADE - Up to 20 LFTHF models - Each system requires 1 cascade sensor per system, and 1 cable for each unit**

Communication Cable (one required for each heater)	FT1861	\$10
Cascade sensor (one required for each cascade system)	FT1868	\$86

# Mini-Therm JX Pricing - Effective December 6, 2021

## Compact Gas-Fired Hydronic Boilers

### Standard Features

- ASME "H" stamp
- Integral low water cutoff
- Digital temperature display
- Rheostat temperature set point
- 7 Economy run modes
- Outdoor reset
- Warm weather shutdown
- Indirect DHW priority
- Spark to pilot ignition
- Low voltage terminal block
- Field interlocks for external devices
- Powered relay contacts for external devices
- Single-point power connection
- Integral base for approved combustible flooring
- Low loss header with boiler pump (125-200)
- Contacts to control boiler pump, system pump and DHW pump
- Built-in draft diverter
- Vent damper included
- Temperature & pressure gauge
- 30psi pressure relief valve
- 20-year limited warranty

### Model Nomenclature

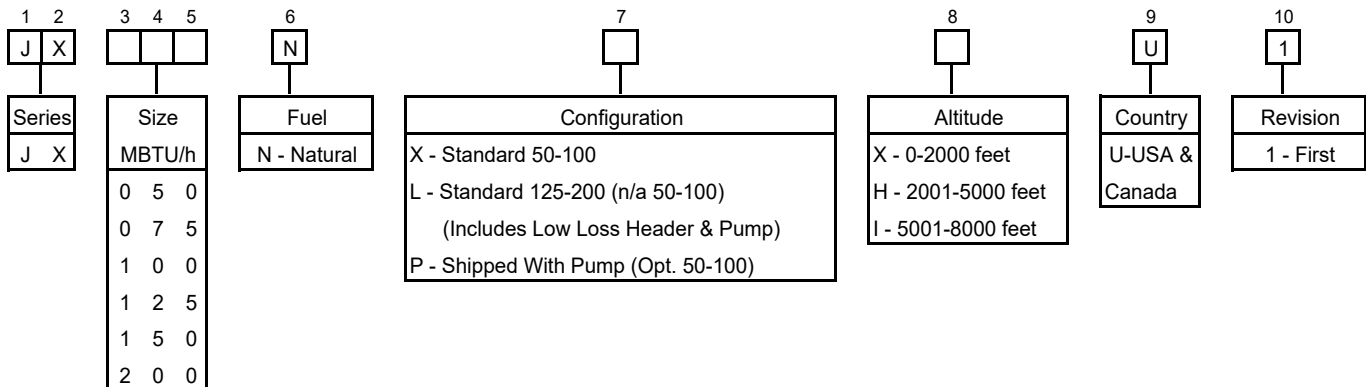

### Pricing

Model	Input Btu / hr	Heating Capacity Btu / hr	A.F.U.E. %	Shipping Weight Lbs	List Price
<b>Models 50-100 Standard</b>					
JX 0 5 0 N X (X, H, I) U 1	50,000	42,000	84	120	\$2,837
JX 0 7 5 N X (X, H, I) U 1	75,000	63,000	84	135	\$3,029
JX 1 0 0 N X (X, H, I) U 1	100,000	84,000	84	145	\$3,336
<b>Models 50-100 With Pump</b>					
JX 0 5 0 N P (X, H, I) U 1	50,000	42,000	84	130	\$3,122
JX 0 7 5 N P (X, H, I) U 1	75,000	63,000	84	145	\$3,313
JX 1 0 0 N P (X, H, I) U 1	100,000	84,000	84	155	\$3,621
<b>Models 125-200 Standard (Includes low loss header &amp; pump assembly)</b>					
JX 1 2 5 N L (X, H, I) U 1	125,000	105,000	84	175	\$3,769
JX 1 5 0 N L (X, H, I) U 1	150,000	126,000	84	185	\$4,014
JX 2 0 0 N L (X, H, I) U 1	199,000	168,000	84	200	\$4,855

## Mini-Therm JX Pricing - Effective December 6, 2021

### Compact Gas-Fired Hydronic Boilers

#### Accessories for Field Mounting

		50	75	100	125	150	200
Low Loss Header & Pump Kit	Kit #	CA019600	CA019600	CA019600	Standard	Standard	Standard
	Price	\$628	\$628	\$628			
Outdoor Air Sensor Kit	Kit #	CA005400	CA005400	CA005400	CA005400	CA005400	CA005400
	Price	\$81	\$81	\$81	\$81	\$81	\$81
DHW Pump Control Kit	Kit #	CA019400	CA019400	CA019400	CA019400	CA019400	CA019400
	Price	\$215	\$215	\$215	\$215	\$215	\$215
Power Vent Kit	Kit #	CA019501	CA019501	CA019501	CA019502	CA019502	CA019502
	Price	\$1,619	\$1,619	\$1,619	\$1,619	\$1,619	\$1,619

#### Conversion Kits

##### Natural to Propane

Altitude		50	75	100	125	150	200
0-2000 feet	Kit #	CA019901	CA019905	CA019909	CA019913	CA019917	CA019921
	Price	\$81	\$90	\$99	\$109	\$119	\$129
2001-5000 feet	Kit #	CA019902	CA019906	CA019910	CA019914	CA019918	CA019922
	Price	\$81	\$90	\$99	\$109	\$119	\$129
5001-8000 feet	Kit #	CA019903	CA019907	CA019911	CA019915	CA019919	CA019923
	Price	\$81	\$90	\$99	\$109	\$119	\$129
8001-10000 feet	Kit #	CA019904	CA019908	CA019912	CA019916	CA019920	CA019924
	Price	\$81	\$90	\$99	\$109	\$119	\$129

##### Natural Gas 8001-10000 feet

Altitude		50	75	100	125	150	200
8001-10000 feet	Kit #	CA020004	CA020008	CA020012	CA020016	CA020020	CA020024
	Price	\$25	\$28	\$33	\$37	\$43	\$51

# Residential Products Pricing and Ordering

## Laars-Stor Indirect Water Heater Pricing - Effective December 6, 2021

Model	Description	Weight		List Price
		Lbs		
<b>Single Wall</b>				
LS-SW-2-30-L	30 gallon	140		\$2,124
LS-SW-2-40R-L	40 gallon	168		\$2,293
LS-SW-2-50R-L	50 gallon	196		\$2,665
LS-SW-2-65-L	65 gallon	196		\$3,061
LS-SW-2-80-L	80 gallon	224		\$3,228
LS-SW-2-120-L	120 gallon	355		\$4,236
<b>Double Wall</b>				
LS-DW240L-464	40 gallon	170		\$2,529
LS-DW250L-464	50 gallon	180		\$2,537
LS-DW265L-464	65 gallon	196		\$2,723
LS-DW280L-464	80 gallon	224		\$2,884

Model	Description	Weight		List Price
		Lbs		
<b>Stainless Steel (single wall)</b>				
LS-SS-30-L	30 gallon	75		\$2,187
LS-SS-40-L	40 gallon	91		\$2,341
LS-SS-50-L	50 gallon	103		\$2,664
LS-SS-75-L	75 gallon	142		\$3,455
LS-SS-120-L	120 gallon	217		\$4,682

## Laars Combi Heat Pricing - Effective December 6, 2021

### Water Heater with Heating Coil

Model	Description	Gas Type	Altitude	Weight	
				Lbs	List Price
<b>Standard Gas</b>					
LCH-504T10FBN	45 gallon, 65 MBTU	Natural	0-2000 feet	238	\$4,796
LCH-504T10FSX	45 gallon, 65 MBTU	Propane	0-2000 feet	238	\$4,796
LCH-75T10BN	72 gallon, 76 MBTU	Natural	0-2000 feet	328	\$5,979
LCH-75T10SX	72 gallon, 76 MBTU	Propane	0-2000 feet	328	\$5,979
LCH-504T10FBN475	45 gallon, 65 MBTU	Natural	2001-7000 feet	238	\$4,796
LCH-504T10FSX475	45 gallon, 65 MBTU	Propane	2001-7000 feet	238	\$4,796
LCH-75T10BN475	72 gallon, 76 MBTU	Natural	2001-7000 feet	328	\$5,979
LCH-75T10SX475	72 gallon, 76 MBTU	Propane	2001-7000 feet	328	\$5,979
<b>Side Wall Vent</b>					
LCH-TW50T10FBN	45 gallon, 65 MBTU	Natural	0-2000 feet	245	\$5,828
LCH-TW50T10FSX	45 gallon, 65 MBTU	Propane	0-2000 feet	245	\$5,828
LCH-TW75T10BN	72 gallon, 76 MBTU	Natural	0-2000 feet	335	\$6,395
LCH-TW75T10SX	72 gallon, 76 MBTU	Propane	0-2000 feet	335	\$6,395
LCH-TW50T10FBN475	45 gallon, 65 MBTU	Natural	2001-7000 feet	245	\$5,828
LCH-TW50T10FSX475	45 gallon, 65 MBTU	Propane	2001-7000 feet	245	\$5,828
LCH-TW75T10BN475	72 gallon, 76 MBTU	Natural	2001-7000 feet	335	\$6,395
LCH-TW75T10SX475	72 gallon, 76 MBTU	Propane	2001-7000 feet	335	\$6,395

Note: These units MUST be ordered for the correct gas. They cannot be converted in the field.

## Buffer / Tempering Tank Pricing - Effective December 6, 2021

### Standard Features

- 20 gallon carbon steel tank
- Heavy duty insulated jacket
- 125 psi working pressure
- 5 year warranty
- Ideal for use with low mass systems, zoned systems, and radiant systems  
\*Not for use with domestic water

### Pricing

Part Number	Description	Weight lbs	List Price
2400-378	20 Gallon Buffer Tank	50	\$1,520

**NOTE: This buffer tank has been discontinued and is limited to remaining stock. Call Customer Service for availability prior to quoting.**

Please visit [www.laars.com/termsandconditions](http://www.laars.com/termsandconditions) to review the complete and current Terms and Conditions for all Laars purchases.



Customer Service and Product Support: 800.900.9276 • Fax 800.559.1583  
 Headquarters: 20 Industrial Way, Rochester, NH, USA 03867 • 603.335.6300 • Fax 603.335.3355  
 9 Brigden Gate, Halton Hills, Ontario, Canada L7G 0A3 • 905.203.0600 • Fax 905.636.0666  
[www.Laars.com](http://www.Laars.com)

Litho in U.S.A. © Laars Heating Systems 21-11 Document 6077AD